

Lecture-11 (Tomasulo+ROB)

CS422-Spring 2020

Biswa@cse-IITK



Tomasulo's Organization

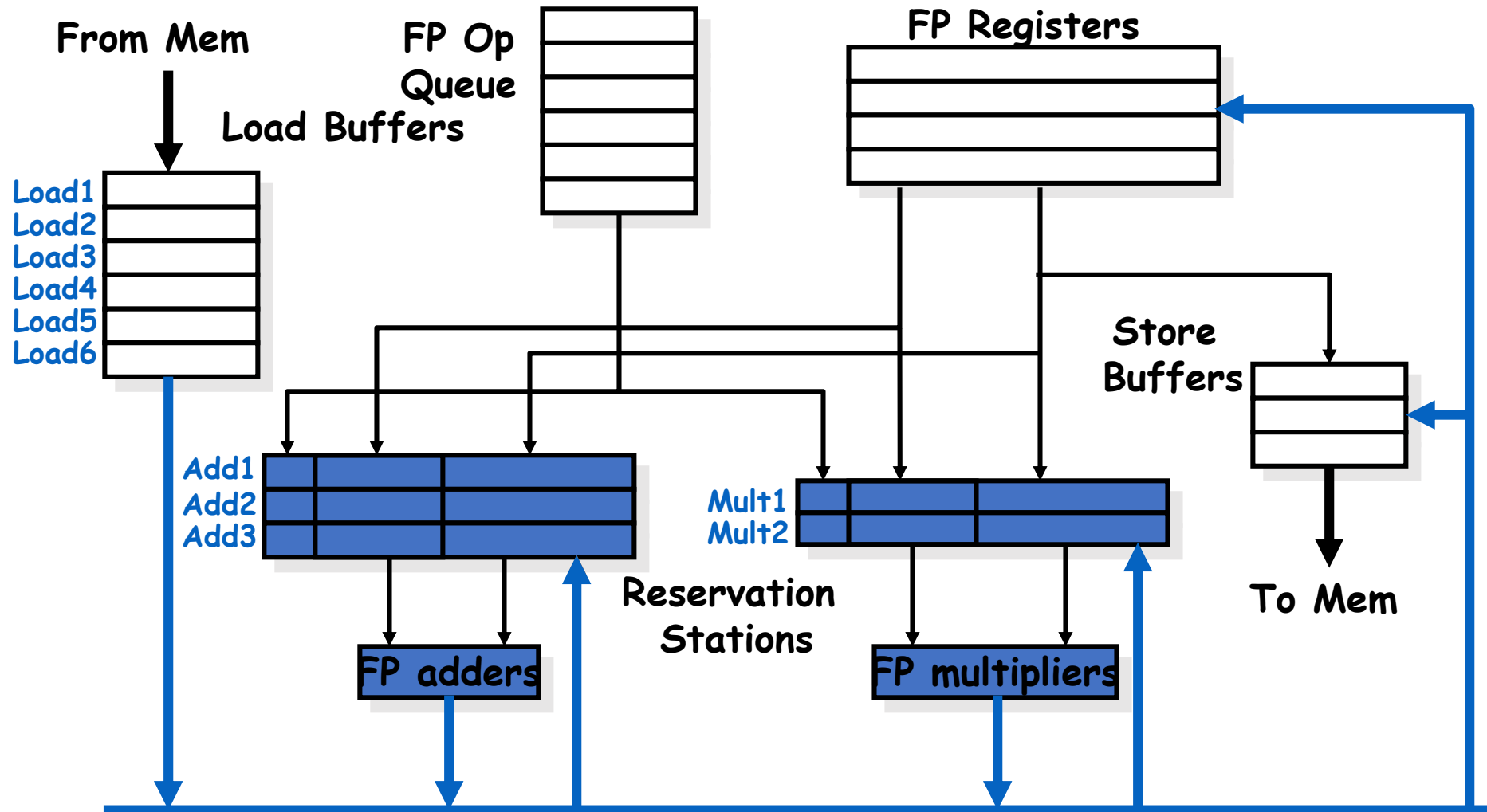

Tomasulo vs Scoreboard

- Control & buffers distributed with Function Units (FU) vs. centralized in scoreboard;
 - FU buffers called “reservation stations”; have pending operands
- Registers in instructions replaced by values or pointers to reservation stations(RS); called register renaming ;
 - avoids WAR, WAW hazards
 - More reservation stations than registers, so can do optimizations compilers can't
- Results to FU from RS, not through registers, over Common Data Bus that broadcasts results to all FUs
- Load and Stores treated as FUs with RSs as wells

Reservation Station Components

Op: Operation to perform in the unit (e.g., + or -)

Vj, Vk: Value of Source operands

- Store buffers has V field, result to be stored

Qj, Qk: Reservation stations producing source registers (value to be written)

- Note: No ready flags as in Scoreboard; $Q_j, Q_k = 0 \Rightarrow$ ready
- Store buffers only have Q_i for RS producing result

Busy: Indicates reservation station or FU is busy

Register result status—Indicates which functional unit will write each register, if one exists. Blank when no pending instructions that will write that register.

Three Stages of Tomasulo Algorithm

1. Issue—get instruction from FP Op Queue

If reservation station free (no structural hazard), control issues instr & sends operands (renames registers).

2. Execution—operate on operands (EX)

When both operands ready then execute;
if not ready, watch Common Data Bus for result

3. Write result—finish execution (WB)

Write on Common Data Bus to all awaiting units;
mark reservation station available

- Normal data bus: data + destination (“go to” bus)
- Common data bus: data + source (“come from” bus)
 - 64 bits of data + 4 bits of Functional Unit source address
 - Write if matches expected Functional Unit (produces result)
 - Does the broadcast

Cycle 1

Instruction status:

Instruction	<i>j</i>	<i>k</i>	Issue	Exec	Write
			Comp	Result	
LD	F6	34+	R2	1	
LD	F2	45+	R3		
MULTD	F0	F2	F4		
SUBD	F8	F6	F2		
DIVD	F10	F0	F6		
ADDD	F6	F8	F2		

	Busy	Address
Load1	Yes	34+R2
Load2	No	
Load3	No	

3 Load Buffers

Load: 2 cycle
 FP add: 2 cycles
 FP multiply: 10 cycles
 FP divide: 40 cycles

Reservation Stations:

Time	Name	Busy	Op	S1 Vj	S2 Vk	RS Qj	RS Qk
	Add1	No					
	Add2	No					
	Add3	No					
	Mult1	No					
	Mult2	No					

FU count
down

3 FP Adder R.S.
2 FP Mult R.S.

Register result status:

Clock	F0	F2	F4	F6	F8	F10	F12	...	F30
1				Load1					

1
 ↑
 Clock cycle
 counter

Cycle 2

Instruction status:

Instruction	<i>j</i>	<i>k</i>	Issue	Exec	Write
			<i>Op</i>	<i>Comp</i>	<i>Result</i>
LD	F6	34+	R2	1	
LD	F2	45+	R3	2	
MULTD	F0	F2	F4		
SUBD	F8	F6	F2		
DIVD	F10	F0	F6		
ADDD	F6	F8	F2		

	Busy	Address
Load1	Yes	34+R2
Load2	Yes	45+R3
Load3	No	

Reservation Stations:

Time	Name	Busy	<i>Op</i>	<i>S1</i> <i>Vj</i>	<i>S2</i> <i>Vk</i>	<i>RS</i> <i>Qj</i>	<i>RS</i> <i>Qk</i>
	Add1	No					
	Add2	No					
	Add3	No					
	Mult1	No					
	Mult2	No					

Register result status:

Clock	F0	F2	F4	F6	F8	F10	F12	...	F30
2		Load2		Load1					

Note: Unlike 6600, can have multiple loads outstanding

Cycle 3

Instruction status:

Instruction	<i>j</i>	<i>k</i>	Issue	Exec Comp	Write Result	Busy	Address
LD	F6	34+	R2	1	3	Load1	Yes 34+R2
LD	F2	45+	R3	2		Load2	Yes 45+R3
MULTD	F0	F2	F4	3		Load3	No
SUBD	F8	F6	F2				
DIVD	F10	F0	F6				
ADDD	F6	F8	F2				

Reservation Stations:

Time	Name	Busy	Op	<i>S1</i> <i>Vj</i>	<i>S2</i> <i>Vk</i>	<i>RS</i> <i>Qj</i>	<i>RS</i> <i>Qk</i>
	Add1	No					
	Add2	No					
	Add3	No					
	Mult1	Yes	MULTD		R(F4)	Load2	
	Mult2	No					

Register result status:

Clock	F0	F2	F4	F6	F8	F10	F12	...	F30
3	Mult1	Load2		Load1					

- Note: registers names are removed ("renamed") in Reservation Stations; MULT issued vs. scoreboard
- Load1 completing; what is waiting for Load1?

Cycle 4

Instruction status:

Instruction	<i>j</i>	<i>k</i>	<i>Issue</i>	<i>Exec Comp</i>	<i>Write Result</i>	Busy	Address	
LD	F6	34+	R2	1	3	4	Load1	No
LD	F2	45+	R3	2	4		Load2	Yes 45+R3
MULTD	F0	F2	F4	3			Load3	No
SUBD	F8	F6	F2	4				
DIVD	F10	F0	F6					
ADDD	F6	F8	F2					

Reservation Stations:

Time	Name	Busy	Op	<i>S1</i> <i>Vj</i>	<i>S2</i> <i>Vk</i>	<i>RS</i> <i>Qj</i>	<i>RS</i> <i>Qk</i>
	Add1	Yes	SUBD	M(A1)			Load2
	Add2	No					
	Add3	No					
	Mult1	Yes	MULTD		R(F4)	Load2	
	Mult2	No					

Register result status:

Clock	F0	F2	F4	F6	F8	F10	F12	...	F30
4	Mult1	Load2		M(A1)	Add1				

- Load2 completing; what is waiting for Load2?

Cycle 5

Instruction status:

Instruction	j	k	Issue	Exec Comp	Write Result	Busy	Address	
LD	F6	34+	R2	1	3	4	Load1	No
LD	F2	45+	R3	2	4	5	Load2	No
MULTD	F0	F2	F4	3			Load3	No
SUBD	F8	F6	F2	4				
DIVD	F10	F0	F6	5				
ADDD	F6	F8	F2					

Reservation Stations:

Time	Name	Busy	Op	$S1$ V_j	$S2$ V_k	RS Q_j	RS Q_k
2	Add1	Yes	SUBD	M(A1)	M(A2)		
	Add2	No					
	Add3	No					
10	Mult1	Yes	MULTD	M(A2)	R(F4)		
	Mult2	Yes	DIVD		M(A1)	Mult1	

Register result status:

Clock	F0	F2	F4	F6	F8	F10	F12	...	F30
5	Mult1	M(A2)		M(A1)	Add1	Mult2			

Timer starts down for Add1, Mult1

Cycle 6

Instruction status:

Instruction	<i>j</i>	<i>k</i>	<i>Issue</i>	<i>Exec Comp</i>	<i>Write Result</i>	Busy	Address	
LD	F6	34+	R2	1	3	4	Load1	No
LD	F2	45+	R3	2	4	5	Load2	No
MULTD	F0	F2	F4	3			Load3	No
SUBD	F8	F6	F2	4				
DIVD	F10	F0	F6	5				
ADDD	F6	F8	F2	6				

Reservation Stations:

<i>Time</i>	<i>Name</i>	<i>Busy</i>	<i>Op</i>	<i>S1 Vj</i>	<i>S2 Vk</i>	<i>RS Qj</i>	<i>RS Qk</i>
1	Add1	Yes	SUBD	M(A1)	M(A2)		
	Add2	Yes	ADDD		M(A2)	Add1	
	Add3	No					
9	Mult1	Yes	MULTD	M(A2)	R(F4)		
	Mult2	Yes	DIVD		M(A1)	Mult1	

Register result status:

Clock	<i>F0</i>	<i>F2</i>	<i>F4</i>	<i>F6</i>	<i>F8</i>	<i>F10</i>	<i>F12</i>	...	<i>F30</i>
6	Mult1	M(A2)		Add2	Add1	Mult2			

- Issue ADDD here vs. scoreboard?

Cycle 7

Instruction status:

Instruction	<i>j</i>	<i>k</i>	<i>Issue</i>	<i>Exec Comp</i>	<i>Write Result</i>	Load	Busy	Address
LD	F6	34+	R2	1	3	4	Load1	No
LD	F2	45+	R3	2	4	5	Load2	No
MULTD	F0	F2	F4	3			Load3	No
SUBD	F8	F6	F2	4	7			
DIVD	F10	F0	F6	5				
ADDD	F6	F8	F2	6				

Reservation Stations:

Time	Name	Busy	Op	<i>S1</i> <i>Vj</i>	<i>S2</i> <i>Vk</i>	<i>RS</i> <i>Qj</i>	<i>RS</i> <i>Qk</i>
0	Add1	Yes	SUBD	M(A1)	M(A2)		
	Add2	Yes	ADDD		M(A2)	Add1	
	Add3	No					
8	Mult1	Yes	MULTD	M(A2)	R(F4)		
	Mult2	Yes	DIVD		M(A1)	Mult1	

Register result status:

Clock	<i>F0</i>	<i>F2</i>	<i>F4</i>	<i>F6</i>	<i>F8</i>	<i>F10</i>	<i>F12</i>	...	<i>F30</i>
7	FU	Mult1	M(A2)	Add2	Add1	Mult2			

- Add1 completing; what is waiting for it?

Cycle 8

Instruction status:

Instruction	<i>j</i>	<i>k</i>	<i>Issue</i>	<i>Exec Comp</i>	<i>Write Result</i>	Busy	Address	
LD	F6	34+	R2	1	3	4	Load1	No
LD	F2	45+	R3	2	4	5	Load2	No
MULTD	F0	F2	F4	3			Load3	No
SUBD	F8	F6	F2	4	7	8		
DIVD	F10	F0	F6	5				
ADDD	F6	F8	F2	6				

Reservation Stations:

<i>Time</i>	<i>Name</i>	<i>Busy</i>	<i>Op</i>	<i>S1 Vj</i>	<i>S2 Vk</i>	<i>RS Qj</i>	<i>RS Qk</i>
	Add1	No					
2	Add2	Yes	ADDD	(M-M)	M(A2)		
	Add3	No					
7	Mult1	Yes	MULTD	M(A2)	R(F4)		
	Mult2	Yes	DIVD		M(A1)	Mult1	

Register result status:

Clock	<i>F0</i>	<i>F2</i>	<i>F4</i>	<i>F6</i>	<i>F8</i>	<i>F10</i>	<i>F12</i>	...	<i>F30</i>
8	Mult1	M(A2)		Add2	(M-M)	Mult2			

Cycle 9

Instruction status:

Instruction	<i>j</i>	<i>k</i>	<i>Issue</i>	<i>Exec</i>	<i>Write</i>	<i>Result</i>	Busy	Address
LD	F6	34+	R2	1	3	4	Load1	No
LD	F2	45+	R3	2	4	5	Load2	No
MULTD	F0	F2	F4	3			Load3	No
SUBD	F8	F6	F2	4	7	8		
DIVD	F10	F0	F6	5				
ADDD	F6	F8	F2	6				

Reservation Stations:

Time	Name	Busy	Op	<i>S1</i>	<i>S2</i>	<i>RS</i>	<i>RS</i>
				<i>Vj</i>	<i>Vk</i>	<i>Qj</i>	<i>Qk</i>
	Add1	No					
1	Add2	Yes	ADDD	(M-M)	M(A2)		
	Add3	No					
6	Mult1	Yes	MULTD	M(A2)	R(F4)		
	Mult2	Yes	DIVD		M(A1)	Mult1	

Register result status:

Clock	<i>F0</i>	<i>F2</i>	<i>F4</i>	<i>F6</i>	<i>F8</i>	<i>F10</i>	<i>F12</i>	...	<i>F30</i>
9	Mult1	M(A2)		Add2	(M-M)	Mult2			

Cycle 10

Instruction status:

Instruction	<i>j</i>	<i>k</i>	<i>Exec Write</i>			Busy	Address	
			<i>Issue</i>	<i>Comp</i>	<i>Result</i>			
LD	F6	34+	R2	1	3	4	Load1	No
LD	F2	45+	R3	2	4	5	Load2	No
MULTD	F0	F2	F4	3			Load3	No
SUBD	F8	F6	F2	4	7	8		
DIVD	F10	F0	F6	5				
ADDD	F6	F8	F2	6	10			

Reservation Stations:

<i>Time</i>	<i>Name</i>	<i>Busy</i>	<i>Op</i>	<i>S1</i>	<i>S2</i>	<i>RS</i>	<i>RS</i>
	Add1	No					
0	Add2	Yes	ADDD	(M-M)	M(A2)		
	Add3	No					
5	Mult1	Yes	MULTD	M(A2)	R(F4)		
	Mult2	Yes	DIVD		M(A1)	Mult1	

Register result status:

Clock	<i>F0</i>	<i>F2</i>	<i>F4</i>	<i>F6</i>	<i>F8</i>	<i>F10</i>	<i>F12</i>	...	<i>F30</i>
10	<i>FU</i>	Mult1	M(A2)	Add2	(M-M)	Mult2			

- Add2 completing; what is waiting for it?

Cycle 11

Instruction status:

Instruction	<i>j</i>	<i>k</i>	<i>Exec Write</i>			Busy	Address	
			<i>Issue</i>	<i>Comp</i>	<i>Result</i>			
LD	F6	34+	R2	1	3	4	Load1	No
LD	F2	45+	R3	2	4	5	Load2	No
MULTD	F0	F2	F4	3			Load3	No
SUBD	F8	F6	F2	4	7	8		
DIVD	F10	F0	F6	5				
ADDD	F6	F8	F2	6	10	11		

Reservation Stations:

Time	Name	Busy	<i>Op</i>	<i>S1</i>	<i>S2</i>	<i>RS</i>	<i>RS</i>
				<i>Vj</i>	<i>Vk</i>	<i>Qj</i>	<i>Qk</i>
	Add1	No					
	Add2	No					
	Add3	No					
4	Mult1	Yes	MULTD	M(A2)	R(F4)		
	Mult2	Yes	DIVD		M(A1)	Mult1	

Register result status:

Clock	<i>F0</i>	<i>F2</i>	<i>F4</i>	<i>F6</i>	<i>F8</i>	<i>F10</i>	<i>F12</i>	...	<i>F30</i>
11	Mult1	M(A2)		(M-M+M)	(M-M)	Mult2			

- Write result of ADDD here vs. scoreboard?
- All quick instructions complete in this cycle!

Cycle 12

Instruction status:

Instruction	<i>j</i>	<i>k</i>	<i>Exec Write</i>			Busy	Address	
			<i>Issue</i>	<i>Comp</i>	<i>Result</i>			
LD	F6	34+	R2	1	3	4	Load1	No
LD	F2	45+	R3	2	4	5	Load2	No
MULTD	F0	F2	F4	3			Load3	No
SUBD	F8	F6	F2	4	7	8		
DIVD	F10	F0	F6	5				
ADDD	F6	F8	F2	6	10	11		

Reservation Stations:

<i>Time</i>	<i>Name</i>	<i>Busy</i>	<i>Op</i>	<i>S1</i>	<i>S2</i>	<i>RS</i>	<i>RS</i>
				<i>Vj</i>	<i>Vk</i>	<i>Qj</i>	<i>Qk</i>
	Add1	No					
	Add2	No					
	Add3	No					
3	Mult1	Yes	MULTD	M(A2)	R(F4)		
	Mult2	Yes	DIVD		M(A1)	Mult1	

Register result status:

Clock	<i>F0</i>	<i>F2</i>	<i>F4</i>	<i>F6</i>	<i>F8</i>	<i>F10</i>	<i>F12</i>	...	<i>F30</i>
12	FU	Mult1	M(A2)		(M-M+N)	(M-M)	Mult2		

Cycle 13

Instruction status:

Instruction	<i>j</i>	<i>k</i>	<i>Exec Write</i>			Busy	Address	
			<i>Issue</i>	<i>Comp</i>	<i>Result</i>			
LD	F6	34+	R2	1	3	4	Load1	No
LD	F2	45+	R3	2	4	5	Load2	No
MULTD	F0	F2	F4	3			Load3	No
SUBD	F8	F6	F2	4	7	8		
DIVD	F10	F0	F6	5				
ADDD	F6	F8	F2	6	10	11		

Reservation Stations:

Time	Name	Busy	<i>Op</i>	<i>S1</i>	<i>S2</i>	<i>RS</i>	<i>RS</i>
				<i>Vj</i>	<i>Vk</i>	<i>Qj</i>	<i>Qk</i>
	Add1	No					
	Add2	No					
	Add3	No					
2	Mult1	Yes	MULTD	M(A2)	R(F4)		
	Mult2	Yes	DIVD		M(A1)	Mult1	

Register result status:

Clock	<i>F0</i>	<i>F2</i>	<i>F4</i>	<i>F6</i>	<i>F8</i>	<i>F10</i>	<i>F12</i>	...	<i>F30</i>
13	Mult1	M(A2)		(M-M+N)	(M-M)	Mult2			

Cycle 14

Instruction status:

Instruction	<i>j</i>	<i>k</i>	<i>Exec Write</i>			Busy	Address	
			<i>Issue</i>	<i>Comp</i>	<i>Result</i>			
LD	F6	34+	R2	1	3	4	Load1	No
LD	F2	45+	R3	2	4	5	Load2	No
MULTD	F0	F2	F4	3			Load3	No
SUBD	F8	F6	F2	4	7	8		
DIVD	F10	F0	F6	5				
ADDD	F6	F8	F2	6	10	11		

Reservation Stations:

Time	Name	Busy	<i>Op</i>	<i>S1</i>	<i>S2</i>	<i>RS</i>	<i>RS</i>
				<i>Vj</i>	<i>Vk</i>	<i>Qj</i>	<i>Qk</i>
	Add1	No					
	Add2	No					
	Add3	No					
1	Mult1	Yes	MULTD	M(A2)	R(F4)		
	Mult2	Yes	DIVD		M(A1)	Mult1	

Register result status:

Clock	F0	F2	F4	F6	F8	F10	F12	...	F30
14	Mult1	M(A2)		(M-M+N)	(M-M)	Mult2			

Cycle 15

Instruction status:

Instruction	<i>j</i>	<i>k</i>	<i>Exec Write</i>			Busy	Address	
			<i>Issue</i>	<i>Comp</i>	<i>Result</i>			
LD	F6	34+	R2	1	3	4	Load1	No
LD	F2	45+	R3	2	4	5	Load2	No
MULTD	F0	F2	F4	3	15		Load3	No
SUBD	F8	F6	F2	4	7	8		
DIVD	F10	F0	F6	5				
ADDD	F6	F8	F2	6	10	11		

Reservation Stations:

<i>Time</i>	<i>Name</i>	<i>Busy</i>	<i>Op</i>	<i>S1</i>	<i>S2</i>	<i>RS</i>	<i>RS</i>
				<i>Vj</i>	<i>Vk</i>	<i>Qj</i>	<i>Qk</i>
	Add1	No					
	Add2	No					
	Add3	No					
0	Mult1	Yes	MULTD	M(A2)	R(F4)		
	Mult2	Yes	DIVD		M(A1)	Mult1	

Register result status:

Clock	<i>F0</i>	<i>F2</i>	<i>F4</i>	<i>F6</i>	<i>F8</i>	<i>F10</i>	<i>F12</i>	...	<i>F30</i>
15	FU	Mult1	M(A2)		(M-M+N)	(M-M)	Mult2		

- **Mult1 (MULTD) completing; what is waiting for it?**

Cycle 16

Instruction status:

Instruction	<i>j</i>	<i>k</i>	<i>Issue</i>	<i>Exec Comp</i>	<i>Write Result</i>	Busy	Address	
LD	F6	34+	R2	1	3	4	Load1	No
LD	F2	45+	R3	2	4	5	Load2	No
MULTD	F0	F2	F4	3	15	16	Load3	No
SUBD	F8	F6	F2	4	7	8		
DIVD	F10	F0	F6	5				
ADDD	F6	F8	F2	6	10	11		

Reservation Stations:

Time	Name	Busy	Op	<i>S1</i> <i>Vj</i>	<i>S2</i> <i>Vk</i>	<i>RS</i> <i>Qj</i>	<i>RS</i> <i>Qk</i>
	Add1	No					
	Add2	No					
	Add3	No					
	Mult1	No					
40	Mult2	Yes	DIVD	M*F4	M(A1)		

Register result status:

Clock	F0	F2	F4	F6	F8	F10	F12	...	F30
16	FU	M*F4	M(A2)		(M-M+N)	(M-M)	Mult2		

- Just waiting for Mult2 (DIVD) to complete

Cycle 55

Instruction status:

Instruction	<i>j</i>	<i>k</i>	<i>Issue</i>	<i>Exec Comp</i>	<i>Write Result</i>	Busy	Address	
LD	F6	34+	R2	1	3	4	Load1	No
LD	F2	45+	R3	2	4	5	Load2	No
MULTD	F0	F2	F4	3	15	16	Load3	No
SUBD	F8	F6	F2	4	7	8		
DIVD	F10	F0	F6	5				
ADDD	F6	F8	F2	6	10	11		

Reservation Stations:

Time	Name	Busy	Op	<i>S1</i> <i>Vj</i>	<i>S2</i> <i>Vk</i>	<i>RS</i> <i>Qj</i>	<i>RS</i> <i>Qk</i>
	Add1	No					
	Add2	No					
	Add3	No					
	Mult1	No					
1	Mult2	Yes	DIVD	M*F4	M(A1)		

Register result status:

Clock	F0	F2	F4	F6	F8	F10	F12	...	F30
55	FU	M*F4	M(A2)	(M-M+N	(M-M)	Mult2			

Cycle 56

Instruction status:

Instruction	<i>j</i>	<i>k</i>	<i>Issue</i>	<i>Exec Comp</i>	<i>Write Result</i>	Busy	Address	
LD	F6	34+	R2	1	3	4	Load1	No
LD	F2	45+	R3	2	4	5	Load2	No
MULTD	F0	F2	F4	3	15	16	Load3	No
SUBD	F8	F6	F2	4	7	8		
DIVD	F10	F0	F6	5	56			
ADDD	F6	F8	F2	6	10	11		

Reservation Stations:

Time	Name	Busy	Op	<i>S1</i> <i>Vj</i>	<i>S2</i> <i>Vk</i>	<i>RS</i> <i>Qj</i>	<i>RS</i> <i>Qk</i>
	Add1	No					
	Add2	No					
	Add3	No					
	Mult1	No					
0	Mult2	Yes	DIVD	M*F4	M(A1)		

Register result status:

Clock	F0	F2	F4	F6	F8	F10	F12	...	F30
56	FU	M*F4	M(A2)		(M-M+N	(M-M)	Mult2		

- Mult2 is completing; what is waiting for it?

Cycle 57

Instruction status:

Instruction	<i>j</i>	<i>k</i>	Issue	Exec Comp	Write Result	Busy	Address
LD	F6	34+	R2	1	3	4	Load1
LD	F2	45+	R3	2	4	5	Load2
MULTD	F0	F2	F4	3	15	16	Load3
SUBD	F8	F6	F2	4	7	8	
DIVD	F10	F0	F6	5	56	57	
ADDD	F6	F8	F2	6	10	11	

Reservation Stations:

Time	Name	Busy	Op	<i>S1</i> <i>Vj</i>	<i>S2</i> <i>Vk</i>	<i>RS</i> <i>Qj</i>	<i>RS</i> <i>Qk</i>
	Add1	No					
	Add2	No					
	Add3	No					
	Mult1	No					
	Mult2	Yes	DIVD	M*F4	M(A1)		

Register result status:

Clock	F0	F2	F4	F6	F8	F10	F12	...	F30
56	FU	M*F4	M(A2)		(M-M+M	(M-M)	Result		

- Once again: In-order issue, out-of-order execution and completion.

Cycle 62

Instruction status:

Instruction	<i>j</i>	<i>k</i>	<i>Issue</i>	<i>Read Oper</i>	<i>Exec Comp</i>	<i>Write Result</i>	
LD	F6	34+	R2	1	2	3	4
LD	F2	45+	R3	5	6	7	8
MULTD	F0	F2	F4	6	9	19	20
SUBD	F8	F6	F2	7	9	11	12
DIVD	F10	F0	F6	8	21	61	62
ADDD	F6	F8	F2	13	14	16	22

<i>Issue</i>	<i>Exec Comp</i>	<i>Write Result</i>
1	3	4
2	4	5
3	15	16
4	7	8
5	56	57
6	10	11

Tomasulo vs Scoreboard

Pipelined Functional Units
(6 load, 3 store, 3 +, 2 x/÷)
window size: ≤ 14 instructions
No issue on structural hazard
WAR: renaming avoids
WAW: renaming avoids
Broadcast results from FU
Control: reservation stations

Multiple Functional Units
(1 load/store, 1 +, 2 x, 1 ÷)
 ≤ 5 instructions
same
stall completion
stall issue
Write/read registers
central scoreboard

Hello World from the ROB

